

1

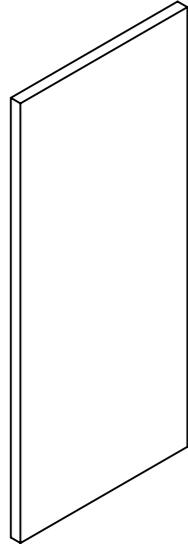

Begin met de voorplaat  
Stop de deuvels in de gaten

2

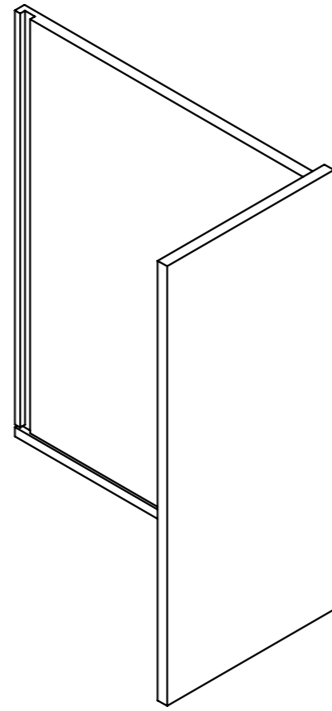

Bevestig de grote zijplaat

3

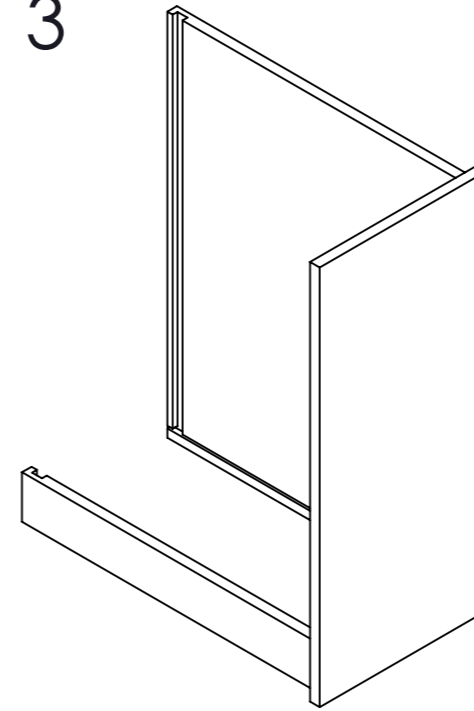

Bevestig de kleine zijplaat

4

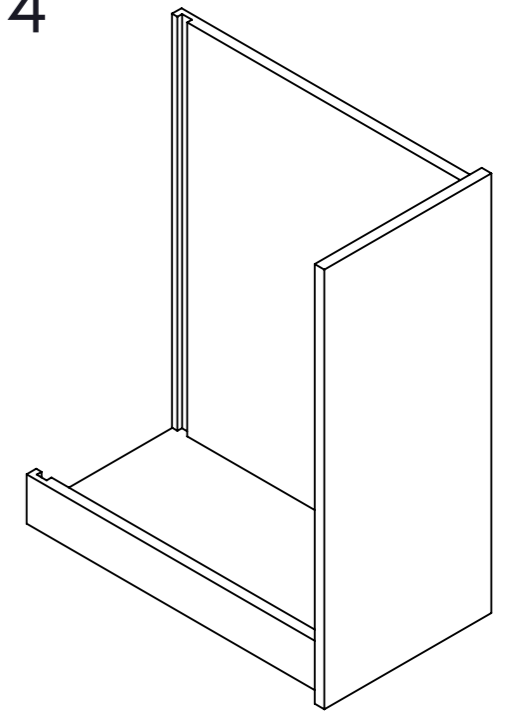

Schuif de bodemplaat in de gleuf

5

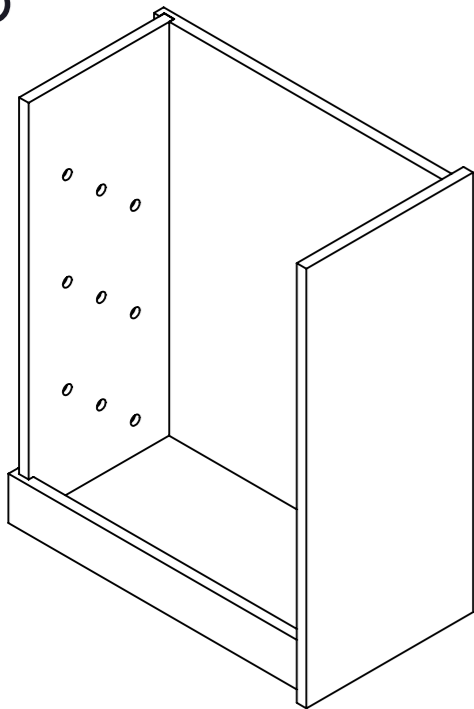

Schuif de achterplaat in de gleuf  
met de gaten op deze manier

6

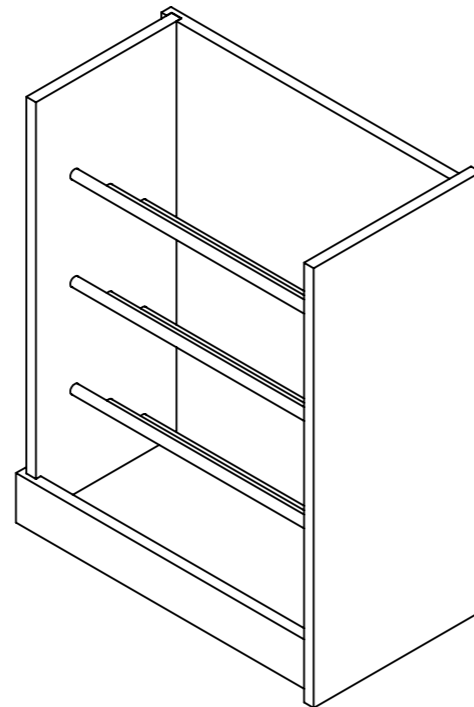

Stop de PVC pijpen in de gaten

7

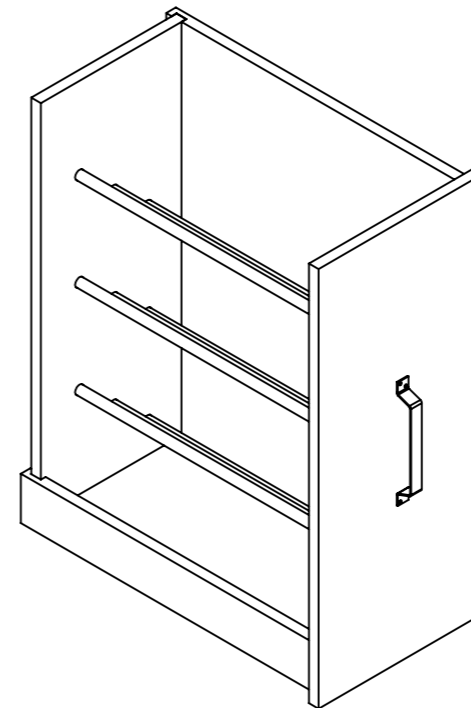

Bevestig de greep  
Dit kan op ieder gewenste manier

8

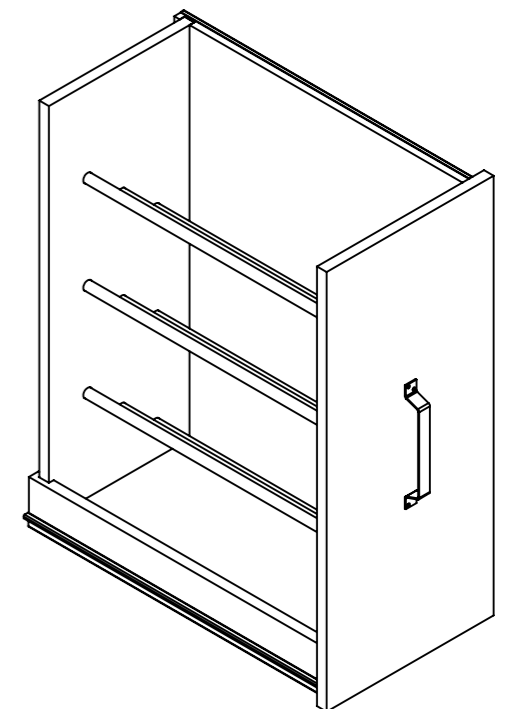

Bevestig de ladegeleiders

Opp. ruwheid (zie NEN 3634)	Maattoleranties NEN-ISO 2768-	MATERIAAL:MDF, PVC en Staal	Vorm- en plaatstol. (zie NEN-ISO11010)
	SCHAAL:1:10	GETEKEND:Koen Bosmans	OPMERKING:
	MAATEENHEID: mm	AFDELING:IPO Engineering	
	DATUM:13-1-21	GEZIEN:	NUMMER:1.1b
		BENAMING:Montagevolgorde lade	<b>A3</b>